

## Index

<b><u>Forward</u></b> .....	<b>02</b>
-----------------------------	-----------

<b><u>Tools Required</u></b> .....	<b>03</b>
------------------------------------	-----------

### Preparation For Construction Of The Form work

<b>1</b>	Bearing surface for walls.....	<b>04</b>
<b>2</b>	Footings.....	<b>05</b>
<b>3</b>	Layout.....	<b>06</b>
<b>4</b>	Placing of Forming units.....	<b>06</b>
	- Track.....	<b>06</b>
	- Rebar.....	<b>06</b>
	- Consulwal forms.....	<b>07</b>
	- Bracing.....	<b>10</b>
	- Bucks for Openings.....	<b>12</b>
<b>5</b>	Intersecting Walls.....	<b>13</b>
<b>6</b>	Pilasters.....	<b>14</b>
<b>7</b>	Wall Fasteners.....	<b>14</b>
<b>8</b>	Services.....	<b>15</b>
<b>9</b>	Requirements for Concrete and Method of Placing.....	<b>15</b>
<b>10</b>	Support of Floor and Roof Systems.....	<b>16</b>
<b>11</b>	Foundation Damp Proofing.....	<b>18</b>
<b>12</b>	Exterior Finishes.....	<b>19</b>
<b>13</b>	Interior Finishes.....	<b>21</b>
<b>14</b>	Summary.....	<b>22</b>

## FORWARD

This technical manual on **Consulwal** construction was prepared to assist designers, builders, and building officials to use this method of construction in a manner consistent with current design practices and the specific requirements of current building codes and the CCMC.

Further assistance in preparation of building plans is available from professional staff experienced in the design and construction utilizing **Consulwal** units.

Although every effort has been made to ensure that all information presented is factual and that all numerical values are accurate to a degree consistent with current design practices, those engaged in the preparation of this manual assume no responsibility for errors or oversights resulting from use of the information contained in this publication.

All suggestions for additions, changes, etc., to this publication are welcome and will receive full consideration for future updates.

The information contained in the following pages are the strict property of **Consulwal**. No reproduction of the information herein shall be allowed unless written consent is given by **Consulwal**. The information herein has been designed strictly for the Consulwal product and any use of this information for any like product could potentially result in serious design flaws.

## **Tools Required**

Measuring Tape

Black Marker

4' Level

Large Square

Hammer

Pruning Saw

Key-hole Saw

Aviation Snips

Chalk Line

String Line

Plumb Bob

Drill c/w Driver Bits

Skill Saw c/w Metal cutting Blade

Rebar Cutter (cuts quick, grinder c/w cutoff wheel)

Wire tie tool

## Preparation For Construction Of The Form work

### 1. Bearing surface for Consulwal Walls

For construction to progress smoothly and to maintain accuracy of line and vertical plumb, it is critical that the first course of **Consulwal** units be started on a **level** bearing surface.

If the bearing surface of strip footings, grade slabs, or floors at upper stories of buildings are uneven or are not level, this must be corrected prior to placing the forming units. There are three basic methods for levelling the bearing surface:

**1.i)** Small irregularities or sloped surfaces can usually be corrected by using mortar or dry packed grout under the first course of Consulwal units. However, the maximum thickness of this mortar joint should normally be limited to **less than 1 inch**.

**1.ii)** Where major irregularities or sloped surfaces occur, the best correction procedure is to place a new layer of concrete topping to produce a flat and level starting surface. Alternatively, it may be possible to chip away original high points on the bearing surface.

**1.iii)** Where, due to elevation restrictions, major irregularities or slopes cannot be corrected by adding surface topping, the **Consulwal** units may be cut so that their bottom surfaces conform to the irregular bearing surface. A technique which has worked well in practice is to lay out the first course of units upside down on the bearing surface, and then using a chalk line as a levelling line, snap a horizontal chalk line onto the upper parts of these units (i.e., as near as possible to the actual bottom of the units). When the bottom parts of the **Consulwal** units are trimmed away, along the chalk line, and the units are returned to their correct orientation, the upper edge of the first course should now be reasonably level. However, some use of mortar under this first course may still be necessary to achieve the required support.

## 2. Footings for Consulwal Concrete Walls

Footings for walls should be designed for the applicable loading and soil conditions. They should be placed on undisturbed soil or on fill which has been reviewed by a soils consultant and then compacted to meet the appropriate building code requirements.

For low load and normal soil conditions, the recommended minimum requirements for a strip footing are shown in the illustration below (see FIGURE 1)

In this case, reinforcing bars are shown as dowels to connect the footings to the wall with a minimum projection of 12 inches.

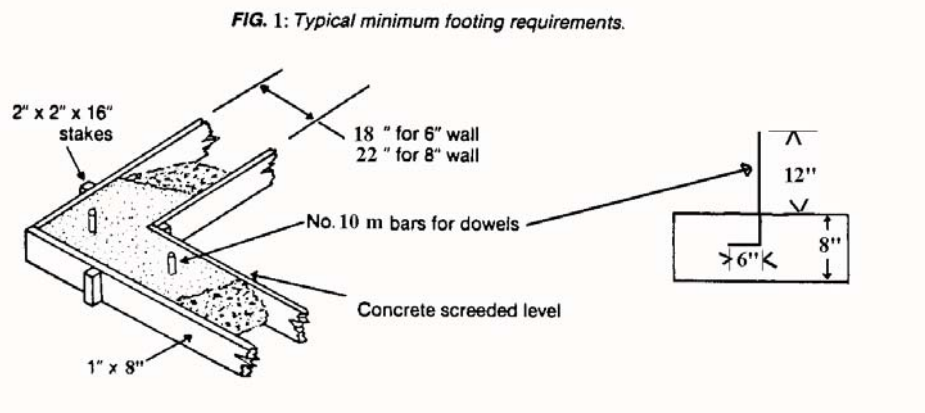

**Fig. 1**

Installation of dimensional pins (corner pins) are placed to reflect the outside perimeter of the foundation walls prior to the pouring of concrete in the footing forms.

(see FIGURE 2)

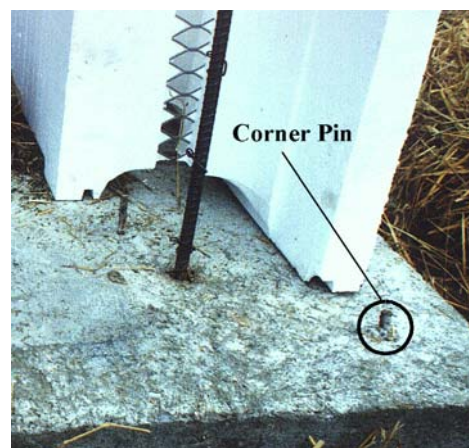

**Fig 2**

### **3. Layout**

**3.i)** Before beginning to place the **Consulwal** units, the inside and outside lines for the walls should be marked. Chalk lines may be snapped onto the footing or slab to correspond to the 11 1/4" or 13 1/4" overall thickness of the units.

**3.ii)** Door and window locations should also be marked as well as any other openings which will need to be formed into the wall as block installation progresses.

### **4. Placing of Form Units, Guides, Bracing, and Bucks for Openings**

#### **4.i Track**

**a)** For footings and interior walls or slabs, anchor our pre-designed metal track or 2 x 4 wood guides along the chalk lines (except at door openings) to serve as guides for the first course of **Consulwal** units. As seen in Fig 4a.

**b)** For walls built at the edge of grade slabs or above grade floors, the pre-designed track should be used as there may not be anything on which to anchor the exterior wood guide.

#### **4. ii) Rebar**

Installation of the vertical rebar must be as per Consulwal's rebar schedule and fastened to the footing anchors prior to the first row of the Consulwal blocks being installed (see FIGURE 3).

Horizontal rebar is installed every third course, unless otherwise noted in the schedule.



**Fig 3**

#### 4. iii Consulwal Forms

a) Install all corner brackets making sure that all are plumb. Supporting the brackets can be done by screwing a board to the foundation track and then to the corner bracket to hold it in place while block is being laid. ( see Figure 4a / 4b)



Fig. 4a



Fig. 4b

b) Standing to the inside of the footing and working left to right place the pre-cut corner block B shown in ( FIGURE 4c), in the guide track (see Figure 4d).

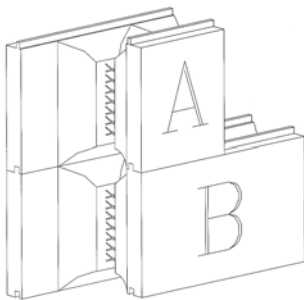
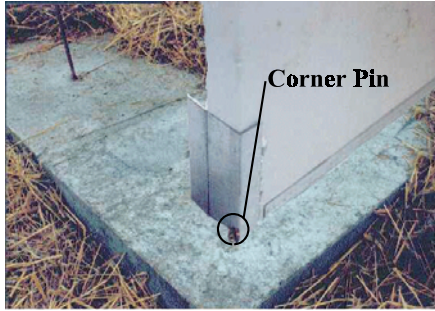

Fig. 4c

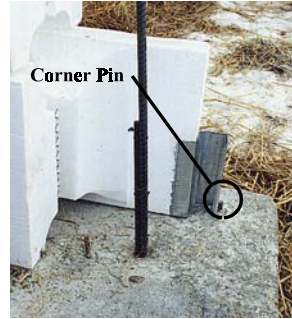

Fig. 4d

By placing the corner block into the track and corner bracket, this will ensure that there will be no movement in the first row of blocks. When using the **Consulwal 6"** block start the corner bracket tight against the dimensional pin (see FIGURE 5). When using the **Consulwal 8"** block start the corner bracket 2 ½" back from the dimensional pin (see FIGURE 5A)

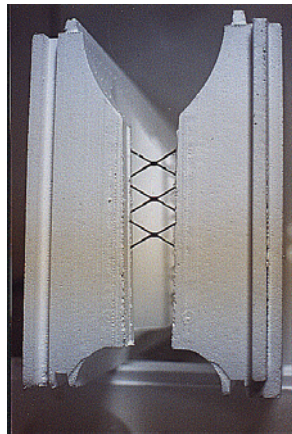

**Fig. 5**

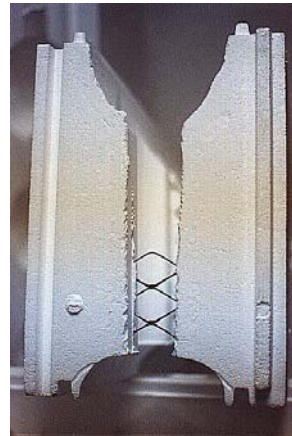

**Fig. 5A**

c) Begin laying of the full block keeping in mind that when placing the full block ensure that the upper mesh (see FIGURE 6) at one end of the block is placed opposite to the lower mesh (see FIGURE 7) on the end of the next block (see FIGURE 8). This will ensure proper concrete flow.



**Fig. 6**



**Fig. 7**

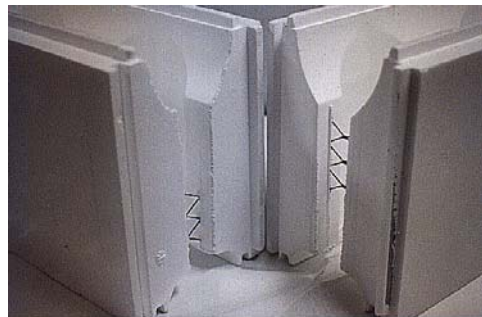

**Fig. 8**

Continue laying the block from the already placed corner blocks along the footing to the next corner.

d) When a full block can no longer be installed proceed to the next corner and repeat steps a, b & c, and continue this procedure clockwise to your starting point.

Once you have reached your starting point you are now ready to complete your first 2 rows by cutting the closing block at each corner.

For the closing block dimension, measure the opening from the last full block to the pre-cut corner block (see FIGURE 9A for 6" block and 9B for the 8" block).

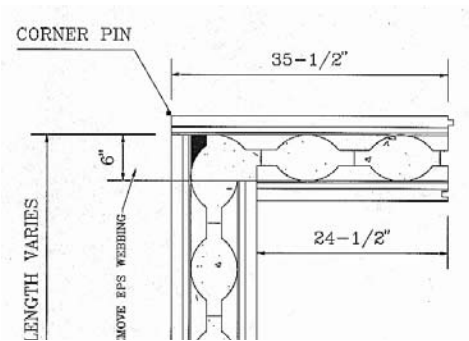

■ REMOVE EPS WEBBING FROM THE CLOSING BLOCK WITHIN THE 6" AS SHOWN ON THE DRAWING

**Fig. 9a**

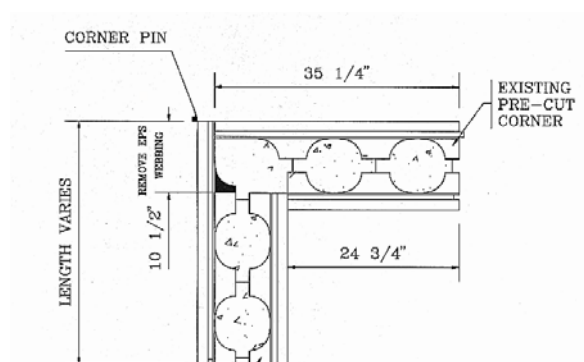

■ REMOVE EPS WEBBING FROM THE CLOSING BLOCK WITHIN THE 10 1/2" AS SHOWN ON THE DRAWING.

**Fig. 9b**

Cut the closing block and install, ( see Figure 9c), continue this procedure for each corner.



**Fig. 9c**

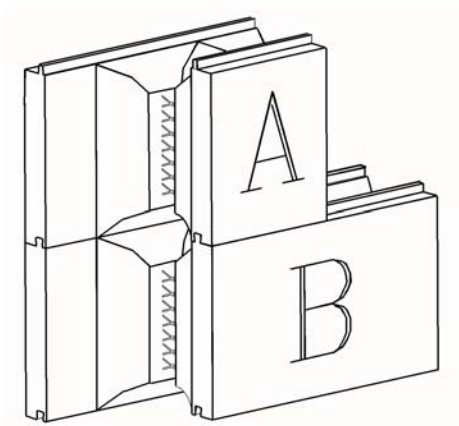

**Fig. 4c**

Once you have completed your first two rows you are now ready to use the same procedure for the remaining rows to the height of your walls (ie Row 1, Row 2, Row 1, Row 2 etc). Ensure that the dimension at the top of the second row is identical to the distance between the dimensional pins at the bottom of the first row.

The closing block cut dimensions for row 1 will be used on rows 3,5,7,9 etc.

The closing block cut dimensions for row 2 will be used on rows 4,6,8,10 etc. At all times your level should be used on the corners to ensure being plumb.

**E)** After the first three courses of **Consulwal** units has been placed, the first level of horizontal reinforcement should be placed and tied to the vertical reinforcement already in place.

Where splices are required, minimum lap lengths of 15" for 10M bars and 18" for 15M bars are required.

**F)**In some cases, users may find it convenient to limit the length of the vertical bars to 4 ft. plus the splice lap length. If windows or other openings exist over this first 4 feet, the appropriate bucks should be accurately located and the **Consulwal** units cut to accommodate these openings. For large openings, additional bracing may be required.

**G)** Prior to placing the first lift of concrete, most **Consulwal** users have found it convenient to cut and place all the remainder of **Consulwal** units required to complete the full height of the wall being poured at this time. Reinforcements should be placed in this construction at this time and following completion of placing the form work, the bracing may be completed.

**With the use of wood guides and adequate bracing, floating or separation of the Consulwal units is not encountered.**

#### **4.iv Bracing**

**a)** Corner bracing should be constructed to run the full storey height on the exterior of a corner (see Figure 10). The function of the corner brace is to ensure plumb and square corners. In addition, it is intended to prevent spreading of the forming units at the corners when mitre cutting of the units may remove the internal webs between the sides of the **Consulwal** units (see Figure 11)



**Fig. 10**



**Fig. 11**

b) Corner bracing should be installed prior to any block being placed, as shown in the illustration below (Fig. 12). The corner brace is attached to the track or wood guides at the base and will need to be braced in both directions near the top of the corner brace.



**Fig. 12**

c) Intermediate wall bracing should be positioned at approximately 6 foot spacing between corners of the building. (use 2" x 6" for walls over 10 feet high), (see FIGURE 13). Only one side of the walls needs to be braced

d) For easier installations a metal bracing system has been designed by **Consulwal** and is available for purchase and/or rental.



Metal



Wood

**Fig. 13**

#### **4.v - Bucks for Openings**

To prepare bucks for doors, windows and other openings, dimensional wood, plywood or preformed plastic forms can be used depending on the thickness of the **Consulwal** units.



**Fig. 14**

Where wood bucks are to remain in the wall, (see Figure 14) wood treated with a preservative must be used. If nailing strips are required, tapered 2" x 2" sections can be lightly nailed outside the bucks to remain embedded in the concrete when the bucks are removed to allow placing of door and window frames.

Door bucks should be positioned along the wall and braced in a manner similar to the intermediate wall braces so that they are kept plumb. These door bucks may be used as intermediate bracing where

they occur (see FIGURE 15).



**Fig 15**

### **5. Intersecting Walls**

At intersecting walls a vertical opening must be cut in the inside face of the exterior **Consulwal** form. This opening should have a width equal to the thickness of the intersecting **Consulwal** units core. Temporary bracing, as shown, may need to be provided on the inside corners of the intersecting walls (see FIGURE 16).

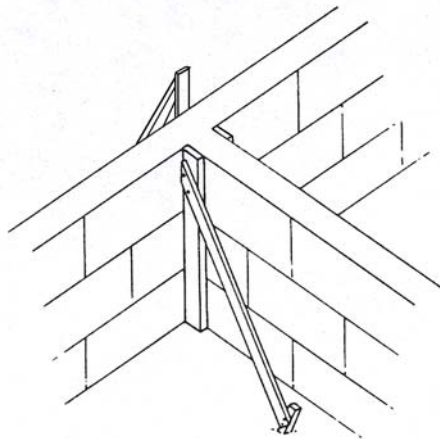

**Fig 16**

These corner braces should be fixed to the guides on both sides of the intersecting wall. In addition, if the webs connecting the sides of the **Consulwal** unit are cut, an exterior brace may be required to prevent the possible spreading outward of the form.

## **6. Pilasters**

Normally there is no need to include pilasters as part of the structural system. However they can be useful in the following cases:

- a) When the wall heights exceed the slenderness ratios allowed by building codes, pilasters can be used to satisfy these requirements by allowing the wall to span horizontally between pilasters.
- b) When high concentrated loads are placed on the wall, pilasters may be necessary to increase the load carrying capacity.
- c) If heavy equipment is to be attached to the wall, it is sometimes more convenient to place pilasters at the required attachment location. One example of when this application may be required is for support of crane rails.

Pilasters may be either interior, exterior, or through the wall. The appropriate size of pilaster may be created by forming up on the desired side(s) of the wall and cutting away the face(s) of the **Consulwal** units located within the formed area.

The following illustrations show a typical interior or exterior intermediate pilaster and a typical through the wall corner pilaster. Pilasters may also be used as corner and intermediate bracing points (see FIGURE 17).

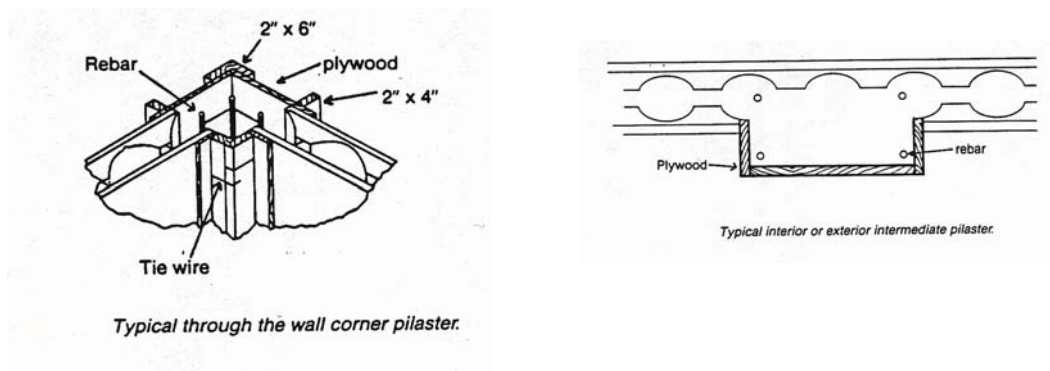

**Fig 17**

## **7. Wall Fasteners**

In some instances there is a need to tie various wall coverings or other devices back to the concrete wall. Where this occurs, it can be efficiently achieved by positioning the tying device(s) through the **Consulwal**

units prior to placing the concrete.

Also, anchor bolts may be accurately located and extended a sufficient distance into the form to provide adequate strength after the concrete has been placed.

## **8. Services**

If electrical, plumbing or other services are intended to be incorporated within the concrete portion of the wall, appropriate conduits or piping will have to be installed within the form work prior to placing the concrete.

## **9. Requirements for Concrete and Method of Placement**

i) The concrete should be proportional to have the specified compressive strength or a minimum of 20MPA. The maximum size of aggregate used should not exceed 3/4" and the slump should be at least 5" but not more than 6". Plasticisers may be used to improve workability.

ii) Depending on the method of placing the concrete, it may be necessary to place a rack over the top of the forms to maintain the alignment along the top of the wall. A typical rack is shown below. The rack can be moved along as the location for placing the concrete is changed (see FIGURE 18).

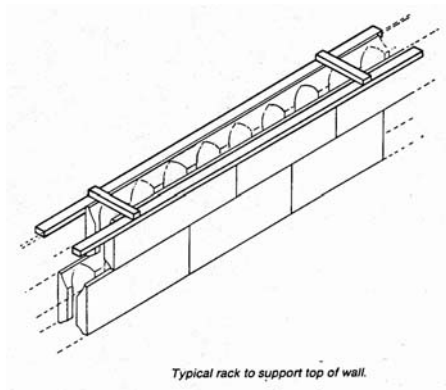

**Fig 18**

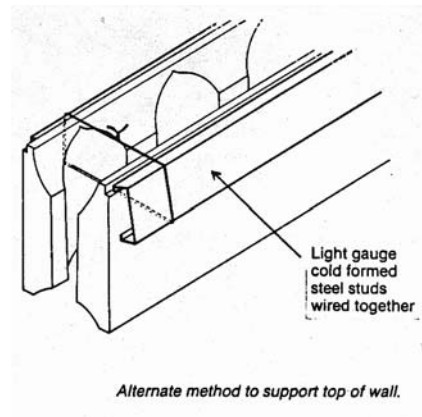

**Fig 19**

iii) Alternately, a procedure which avoids the interference of the cross-strips in the rack is to use light gauge cold formed steel studs wired together along the top of the form work as shown (see FIGURE 19).

iv) Pumping of concrete is the preferred method of placement. The impact of the concrete can be

reduced either by directing the flow of the concrete horizontally and parallel to the wall so that the kinetic energy is dissipated by contact with the metal webs of the **Consulwal** units.

v) Placing concrete from wheelbarrows, buckets, or directly from the chute of a ready-mix truck is an alternative for very small jobs or where a concrete pump is not otherwise available.

vi) After the first 4' lift of concrete has been placed, you should allow 20 min. between lifts, depending on the weather and the age of concrete, in order to let the concrete begin to set up.

For walls over 4' high, scaffolding is necessary to allow placement of concrete in the **Consulwal** units. It is necessary to allow the pumping of the concrete to continue in an efficient and well controlled manner.

This sequence of construction can continue in 4' increments for buildings up to 2 stories high or equivalent single storey types of buildings (i.e., for commercial or industrial uses).

For higher buildings, similar procedures may be used but time must be allowed for the concrete to gain sufficient strength to support the upper stories. Schedules for such construction must be approved by a Structural Engineer and adhere to local building codes.

## **10. Support of Floor and Roof Systems**

i) For basements or when floor slabs are poured on grade, the position of the concrete floor relative to the foundation wall will depend on the requirements for lateral support at the base of the foundation wall.

If extra lateral support is required then, as is shown, the polystyrene on the interior face of the unit will have to be routed out to permit the concrete floor to directly bear against the concrete part of the wall (see FIGURE 20).

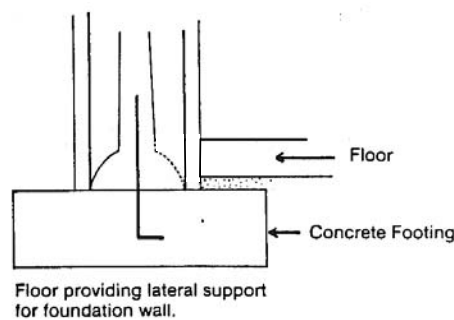

**Fig 20**

*Typical basement floor details.*

ii) For wood floor and roof construction, there are several established methods of providing support.

ii a) If the "Consulwal" concrete walls are only used as foundation walls, anchor bolts should be located in the top of the wall during placing of the concrete to fasten down a wood base plate.

This will serve as the base for standard wood floor construction.

For support of roof rafters or trusses, the same approach may be followed as is shown in the illustration below (see FIGURE 21).

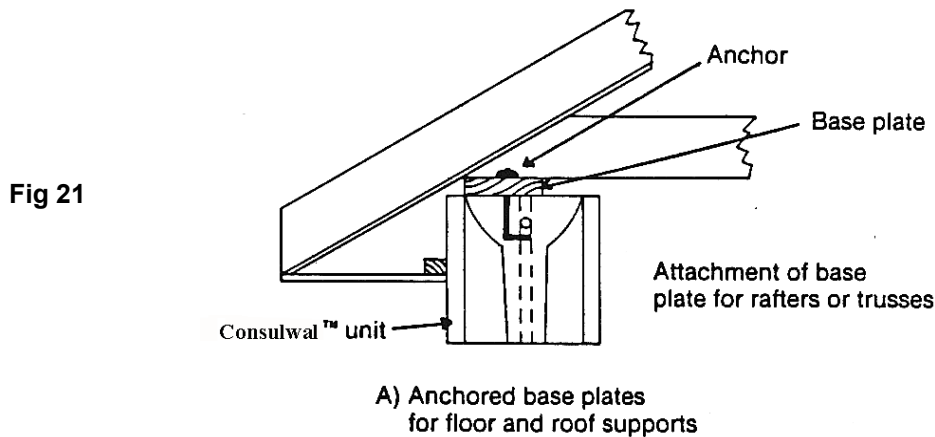

ii b) Wood floor joists can be supported directly in the concrete wall by cutting slots in the Consulwal units. Then, with the fire cut ends of the joists inserted through the slots, the concrete can be placed in the forms around them.

Prior to placing the concrete around the joists, they may be supported either directly on concrete (which was previously poured up to the level of the bottom of the joists) or a temporary support can be used to level and support the floor joists until the concrete has hardened.

**Note:** It should be remembered that any wood in contact with concrete be treated with a preservative.

ii c) Construction using a ledger to support joist hangers can be added so as to allow construction of

the concrete wall to continue past a floor level. In this case a 4" round piece of the polystyrene face of the **Consulwal** units, every 2' on centre, on the floor side of the wall must be cut out to permit the ledger to be supported directly against the concrete. Anchor bolts or other mechanical fastening devices must be used to tie the ledger to the concrete wall. Anchor bolts may then be pre-positioned in the wall by temporarily mounting the ledger on the inside of the form, before placing the concrete. This ensures the match of the anchor bolts and bolt holes in the ledger beam.

iii) Use of the concrete walls to support cast-in-place concrete floor and roof slabs and precast concrete slabs should follow normal practice for the bearing area and continuity provided by reinforcement.

Specific requirements are very much dependant on the design and therefore no standard or minimum requirements are provided here.

To avoid thermal bridging at the floor levels for exterior walls, it is recommended that the **Consulwal** units be continued past the floor or roof levels and the concreting of the walls be stopped off at the level of the bottom of the floor before construction of the floor commences.

The cast-in-place floor or concreting around the ends of the precast floor should be completed prior to forming the walls above this floor level.

iv) Steel joist construction or beam and girder floor systems can also be easily accommodated on the concrete walls. It is important that the bearing plates for these steel members be either located directly over the thickest vertical sections of the wall or that the elevation of these plates be planned to correspond with the thickest horizontal section at the top on the **Consulwal** units. Normally, it is recommended that these members be placed on the wall and anchored in place as construction progresses.

In some special cases, it may be desirable to form pockets in the walls which will allow the steel members to be positioned later. Anchorage and bearing should follow normal design practice.

## **11. Foundation Dampproofing**

The specific design conditions will normally dictate what type of damp-proofing is required.

i) Where foundation walls do not enclose user space, there may not be any need to damp-proof the exterior wall below grade, provided that the soil is well drained or that a damp-proof course is placed through

the wall below the first floor.

ii) Where a significant part of the basement or foundation wall is above grade, use of cement parging is an effective method for protecting the polystyrene surface of the wall. For crack control, wire mesh should be used in the parging. Tying of the wire mesh back to the **Consulwal** wall studs will provide mechanical anchorage of this covering in addition to the bond of parging to the polystyrene.

Although polystyrene itself is relatively impermeable, a bituminous coating or other waterproof membrane should be applied to the below grade surface of the parging.

iii) For below grade construction, an alternative to the second method (described above) is to apply a chemically compatible waterproof coating or a waterproof membrane directly onto the exterior face of the **Consulwal** units.

Depending on the severity of the backfill conditions, it may be necessary to use some type of impact resistant material to protect the Damp proofing. In cold climates, a protective sheathing may be considered to also prevent the soil from freezing directly to the Damp proofing membrane.

Damp proofing should be continued down the foundation wall and extended to the footing. Where cement parging is used, a cove should be formed at this level to provide a transition point from the wall to the footing.

## **12. Provisions for Exterior Finishes**

i) Stucco or other forms of cement parging can be constructed using mesh tied back to the **Consulwal** metal studs. The procedure is similar to that for parging of foundation walls.

ii) For use of proprietary products developed to provide exterior covering for polystyrene, reference should be made to the manufactures application procedures and technical literature.

iii) Horizontally running metal or plastic siding may be attached directly to the wall using the **Consulwal** metal studs (see FIGURE 22).



**Fig 22**



**Fig 23**

iv) Vertically running metal or plastic siding can be attached to furring strips which have been fastened directly to the **Consulwal** studs (see FIGURE 23).

v) Wood siding should not be directly attached to the **Consulwal** studs so the walls are to be strapped prior to installation of the siding (see FIGURE 23)

vi) Steel supports for brick veneer may be installed after the wall is concreted by routing out the outside facing of the **Consulwal** unit and attaching a shelf angle directly to the hardened concrete. The shelf angle must be anchored to the thickest parts of the concrete walls with anchors equivalent to a 5/8" diameter bolt at 3' spacing.

vii) Anchor bolts may be placed through the **Consulwal** units prior to placing the concrete. Otherwise, mechanical anchors drilled into the concrete may also be used.

viii) As an alternative to providing steel supports for the veneer, the concrete wall may be thickened to provide a corbel (a concrete ledge).

The exterior side of the **Consulwal** unit must be cut away and appropriate wood forms secured in place.

Reinforcing and sizing of the corbel should be as

shown or as may otherwise be designed (see FIGURE 24a,b,c,d).

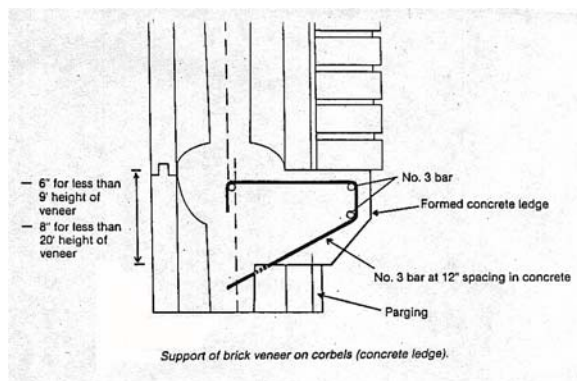

Fig 24a

Fig 24b



Fig 24c

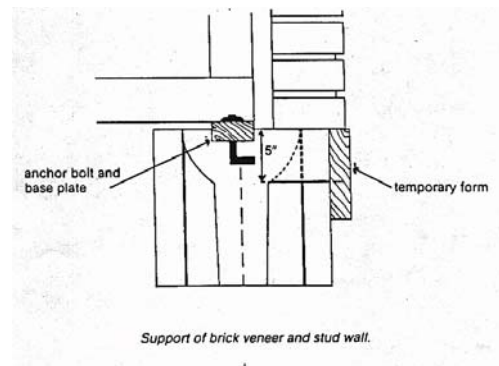

Fig 24d

ix) Where brick veneer and stud walls are supported on the Consulwal walls, both the base plate for the stud wall and at least 2/3 or all but 1 1/4" of the thickness of the brick must be supported on the wall (see FIGURE 24d).

In addition, the outside face of the brick must extend out beyond the exterior face a sufficient distance to cover the parging or other exterior surface coating on the **Consulwal** units.

One of the simplest procedures to follow is to cut away the top 8 inches from the outside of the form and create a form to allow the concrete to extend out to the face of the **Consulwal** unit and thus provide a 1 1/2" corbel or ledge.

### **13. Provisions for Interior Finishes**

i) Interior plaster or stucco finishes (acrylic stucco or fibreglass mesh) may be reinforced with wire mesh and fastened back to the Consulwal studs in the same manner as for exterior parging or stucco finishes.

ii) The most commonly performed method of securing drywall is to screw the drywall directly to the **Consulwal** metal studs on 12" centres.

iii) In some cases, gluing of wall panelling to the surface of the **Consulwal** units will provide adequate support.

iv) When a heavy wall fixture or cabinet must be supported, it is recommended that you attach it directly to the concrete by placing a 2 x 2 furring strip in a routed out slot in the **Consulwal** section.

When the 2 x 2 is mechanically fastened to the concrete it will serve as a solid base for supporting heavy objects. The mechanical anchorage should be to the thicker sections of the wall.

Install a sheet of 3/4" plywood from floor to ceiling where mill work is to be applied, screwing the plywood directly to the **Consulwal** metal studs.

### **Summary**

While the preceding information should facilitate the installation of the **Consulwal** product, as always, various situations will arise whereby additional information is required.

We at **Consulwal** are able to provide whatever technical support, and/or additional information which may be required, to assist with the installation of our product.

We encourage your comments and/or inquiries relating to our product.